

# GP2D120

## Distance Measuring Sensor

Issue Date: August 30, 1999  
No: ED-99170

---

ED-99170	August 30, 1999
MODEL No. GP2D120	PAGE 1/9

**REFERENCE**

1. Application

This specification applies to the outline and characteristics for analog output type distance measuring sensor, Model No. GP2D120.

2. Outline

Refer to the attached drawing No. SOD03596.

3. Ratings and characteristics

3-1 Constitution diagram : Refer to the attached sheet, page 4.

3-2 Absolute maximum ratings : Refer to the attached sheet, page 4.

3-3 Electro-optical Characteristics : Refer to the attached sheet, page 5.

3-4 Timing chart : Refer to the attached sheet, page 5.

4. Reliability

Refer to the attached sheet, page 6.

5. Incoming inspection

Refer to the attached sheet, page 7.

6. Supplement

6-1 GP2D120 Example of Output distance characteristics

Refer to the attached sheet, page 8.

6-2 GP2D120 Example of output characteristics with inverse number of distance

Refer to the attached sheet, page 9.

6-3 ODS materials

This product shall not contain the following materials.  
Also, the following materials shall not be used in the production process for this product.

Materials for ODS : CFC<sub>s</sub>, Halon, Carbon tetrachloride,  
1,1,1-Trichloroethane (Methylchloroform)

6-4 Brominated flame retardants

Specific brominated flame retardants such as the PBBO<sub>s</sub> and PBB<sub>s</sub> are not used in this device at all.

6-5 Product mass : 3.6g (TYP.)

7. Notes

- 7-1 Lens of this device shall be kept cleanly. There are cases that dust, water or oil and so on deteriorate the characteristics of this device. Please consider in actual application.
- 7-2 In case that protection cover is set in front of the emitter and detector portion, the protection cover which has the most efficient transmittance at the emitting wavelength range of LED for the GP2D120 ( $\lambda=850\text{nm}\pm 70\text{nm}$ ), shall be recommended to use. The face and back of protection cover should be mirror polishing. Also, as there are cases that the characteristics may not be satisfied with according to the distance between the protection cover and the GP2D120 or the thickness of the protection cover, please use the GP2D120 after confirming the operation sufficiently in actual application.
- 7-3 In case that there is an object near to light exits of the sensor between the sensor and the detected object, please use this device after confirming sufficiently what the characteristics of this sensor do not change by the object.
- 7-4 When the detector surface receive direct light from the sun, Tungsten lamp and so on, there are cases that it can not measure the distance exactly. Please consider the design that the detector does not receive direct light from such light source.
- 7-5 Distance between sensor and mirror reflector can not sometimes measure exactly. In case of changing the mounting angle of the GP2D120, it may measure the distance exactly.
- 7-6 In case that reflective object has boundary line clearly, there is cases that distance can not measure exactly. At that time, if direction of boundary line and the line between emitter center and detector center parallels, it is possible to decrease deviation of measuring distance.

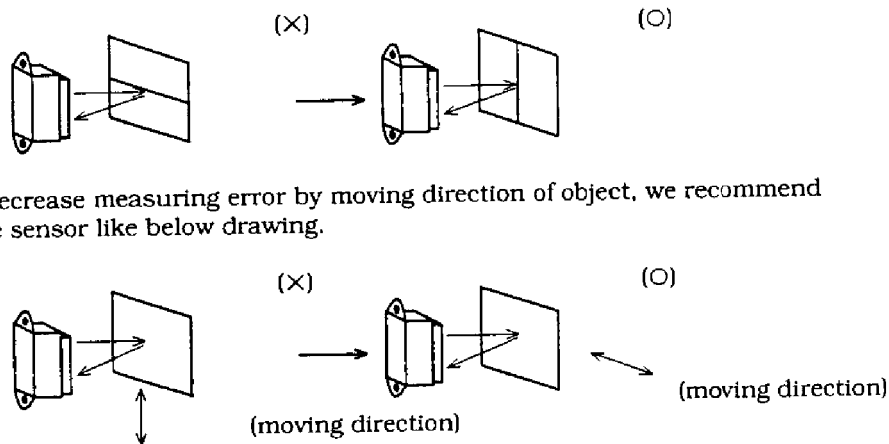

- 7-7 In order to decrease measuring error by moving direction of object, we recommend to mount the sensor like below drawing.

- 7-8 In order to stabilize power supply line, we recommend to connect a by-pass capacitor of  $10\ \mu\text{F}$  or more between Vcc and GND near the GP2D120.
- 7-9 Please don't do washing. Washing may deteriorate the characteristics of optical system and so on.
- 7-10 There are some possibilities that the sensor inside the case package with lens may be exposed to the excessive mechanical stress. Please be careful not to cause any excessive pressure on the case package with lens and also on the PCB at the assembly and inserting of the set .

ED-99170	August 30, 1999
MODEL No. GP2D120	PAGE 3/9

2. Outline (Drawing No. SOD03596)

Scale : 2/1

Unit : mm

Stamp

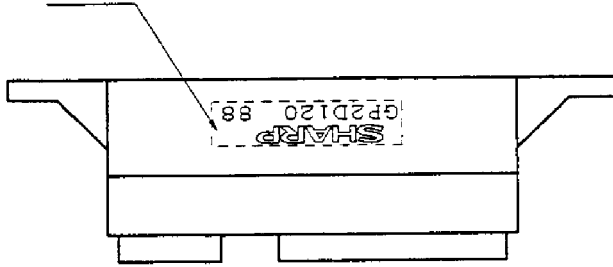

Stamp (Example)

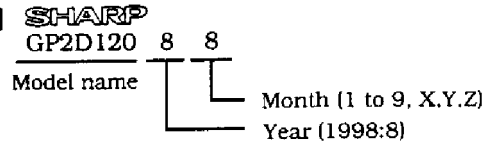

Light emitter side

Light detector side

Lens case

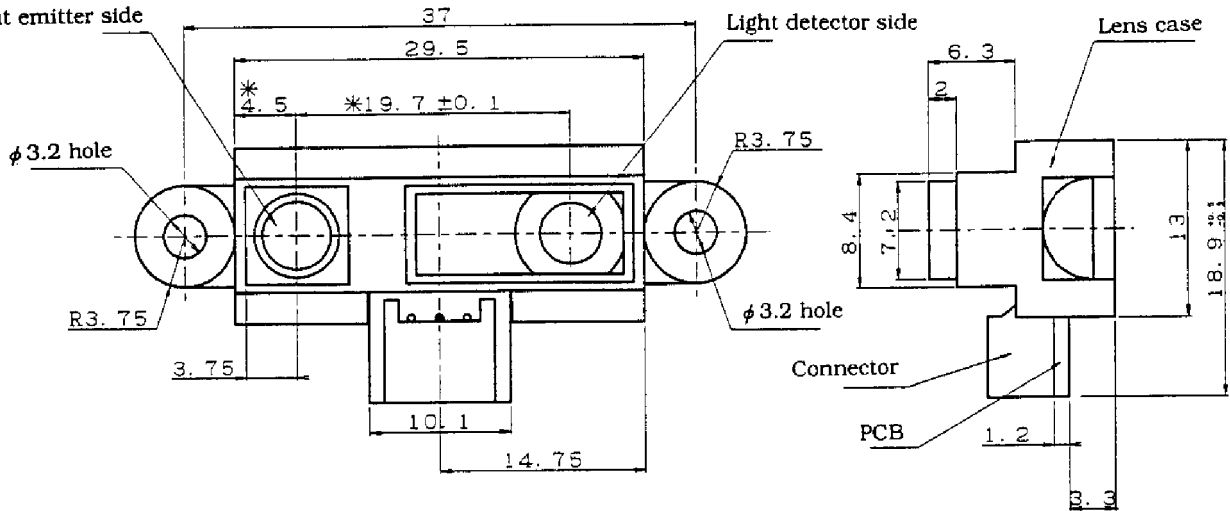

Connector signal

	Signal name
①	V <sub>o</sub>
②	GND
③	V <sub>cc</sub>

Connector : J.S.T. TRADING COMPANY, LTD.  
S3B-PH

Note 1) \* dimension shall be reference lens center.

Note 2) Unspecified tolerance shall be ±0.3mm.

### 3. Ratings and characteristics

#### 3-1 Constitution diagram

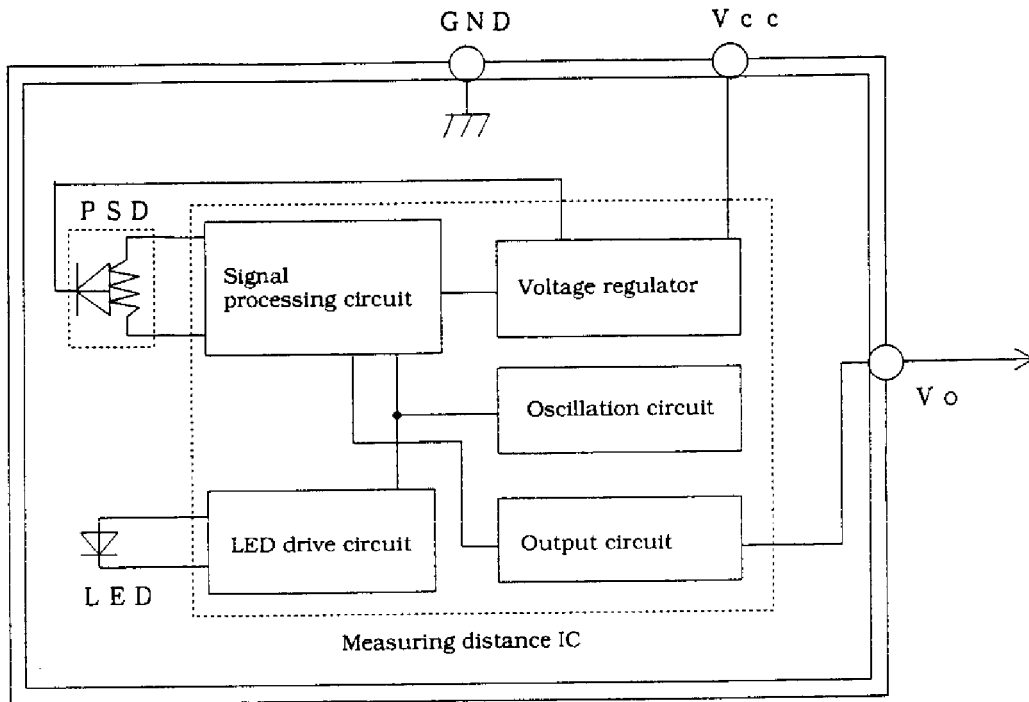

#### 3-2 Absolute maximum ratings

(Ta=25°C, Vcc=5V)

Parameter	Symbol	Rating	Unit	Remark
Supply voltage	Vcc	-0.3 to +7	V	
Output terminal voltage	Vo	-0.3 to Vcc+0.3	V	
Operating temperature	Topr	-10 to +60	°C	
Storage temperature	Tstg	-40 to +70	°C	

#### · Operating Supply Voltage

Parameter	Symbol	Rating	Unit	Remark
Operating Supply Voltage	Vcc	4.5 to 5.5	V	

### 3-3 Electro-optical Characteristics

(Ta=25°C, Vcc=5V)

Parameter	Symbol	Conditions	Min.	Typ.	Max.	Unit
Measuring distance range	$\Delta L$	(*1)	4	-	30	cm
Output terminal voltage	$V_o$	L=30cm (*1)	0.25	0.4	0.55	V
Output voltage difference	$\Delta V_o$	Output change at L change (30cm → 4cm) (*1)	1.95	2.25	2.55	V
Average supply current	$I_{cc}$	L=30cm (*1)	-	33	50	mA

※ L : Distance to reflective object

(\*1) Using reflective object : White paper (Made by Kodak Co. Ltd. gray cards R-27 · white face, reflective ratio ; 90%)

### 3-4 Timing chart

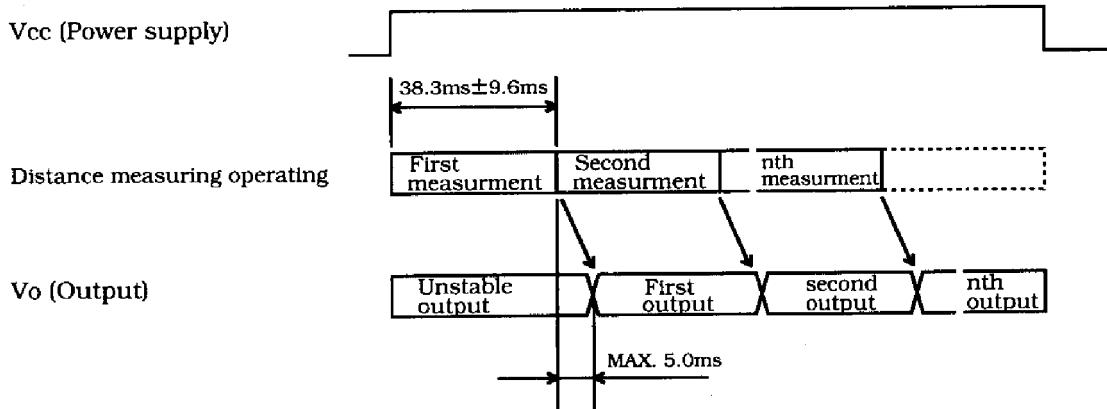

4. Reliability

The reliability of products shall satisfy items listed below.

Confidence level : 90%  
LTPD : 20%/40%

No.	Test Items	Test Conditions	Failure Judgement Criteria	Samples (n) Defective(C)
1	Temperature cycling	1 cycle -40°C ↔ +70°C (30min) (30min) 25 cycles test	Initial $\times 0.8 > V_o$ $V_o > \text{Initial} \times 1.2$ (*1)	n=11, C=0
2	High temp. and high humidity storage	+40°C, 90%RH, 500h		n=11, C=0
3	High temp. storage	+70°C, 500h		n=11, C=0
4	Low temp. storage	-40°C, 500h		n=11, C=0
5	Operation life (High temp.)	+60°C, Vcc=5V, 500h		n=11, C=0
6	Mechanical shock	100m/s <sup>2</sup> , 6.0ms 3times/±X, ±Y, ±Z direction		n= 6 , C=0
7	Variable frequency vibration	10 to 55 to 10Hz/1min Overall amplitude : 1.5mm 2h/X, Y, Z direction		n= 6 , C=0

\*1 Test conditions are according to 3-3 Electro-optical characteristics.

\*2 After test, measurement shall be measured after leaving under the normal temperature and the normal humidity for two hours. But, no dew point.

5. Incoming inspection

(1) Inspection lot

Inspection shall be carried out per each delivery lot.

(2) Inspection method

A single sampling plan, normal inspection level II based on ISO 2859 shall be adopted.

Defect	Inspection items and test method	AQL(%)
Major defect	Electro-optical characteristics defect (In para. 3-3)	0.4
Minor defect	Defect on appearance and dimension * Split, chip, scratch, stain	1.0

\* Split  
Chip  
Scratch  
Stain

One which affects the characteristics of para. 3-3 shall be defect.



6-1 GP2D120 Example of Output distance characteristics

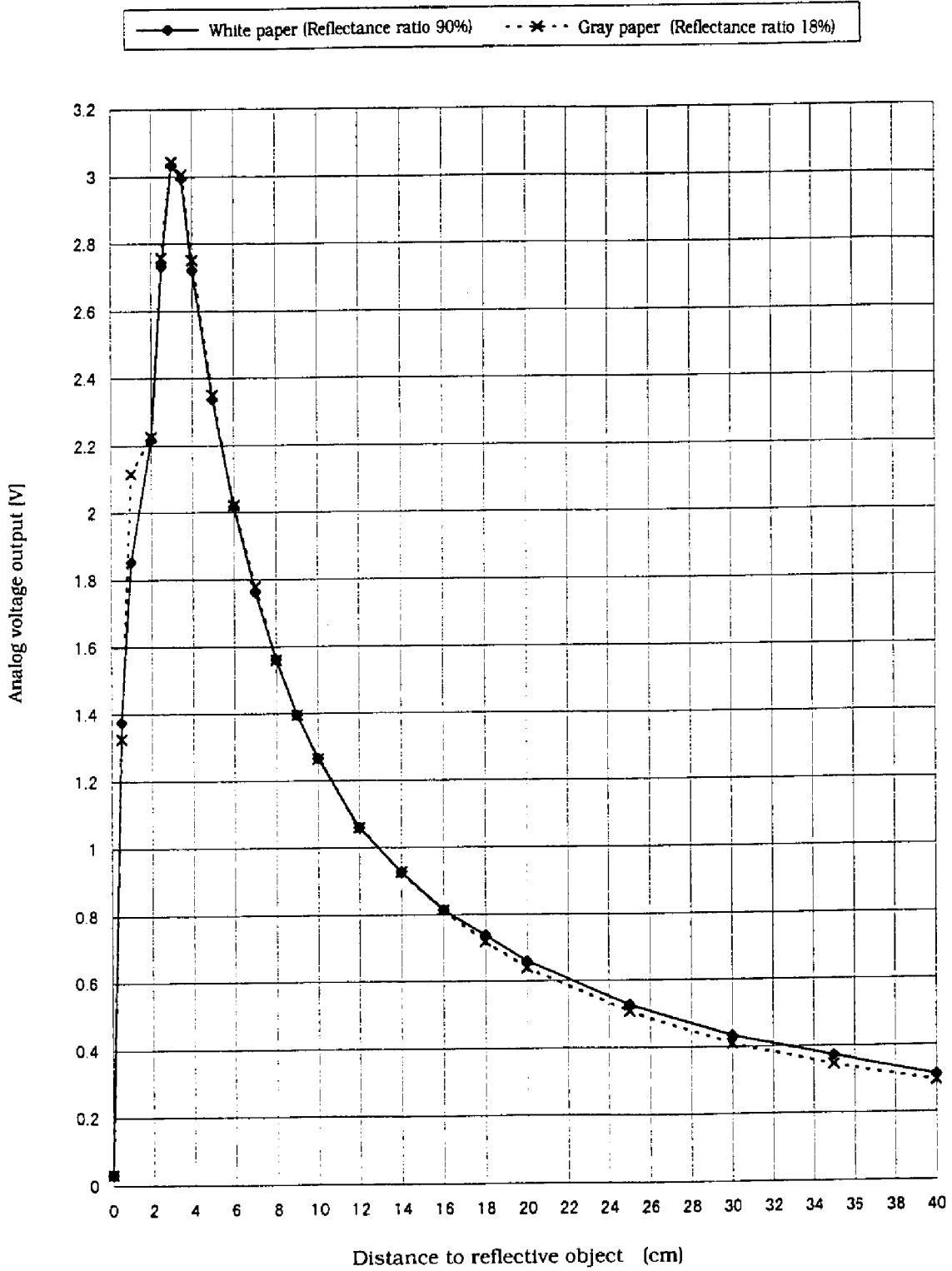

6-2 GP2D120 Example of output characteristics with inverse number of distance

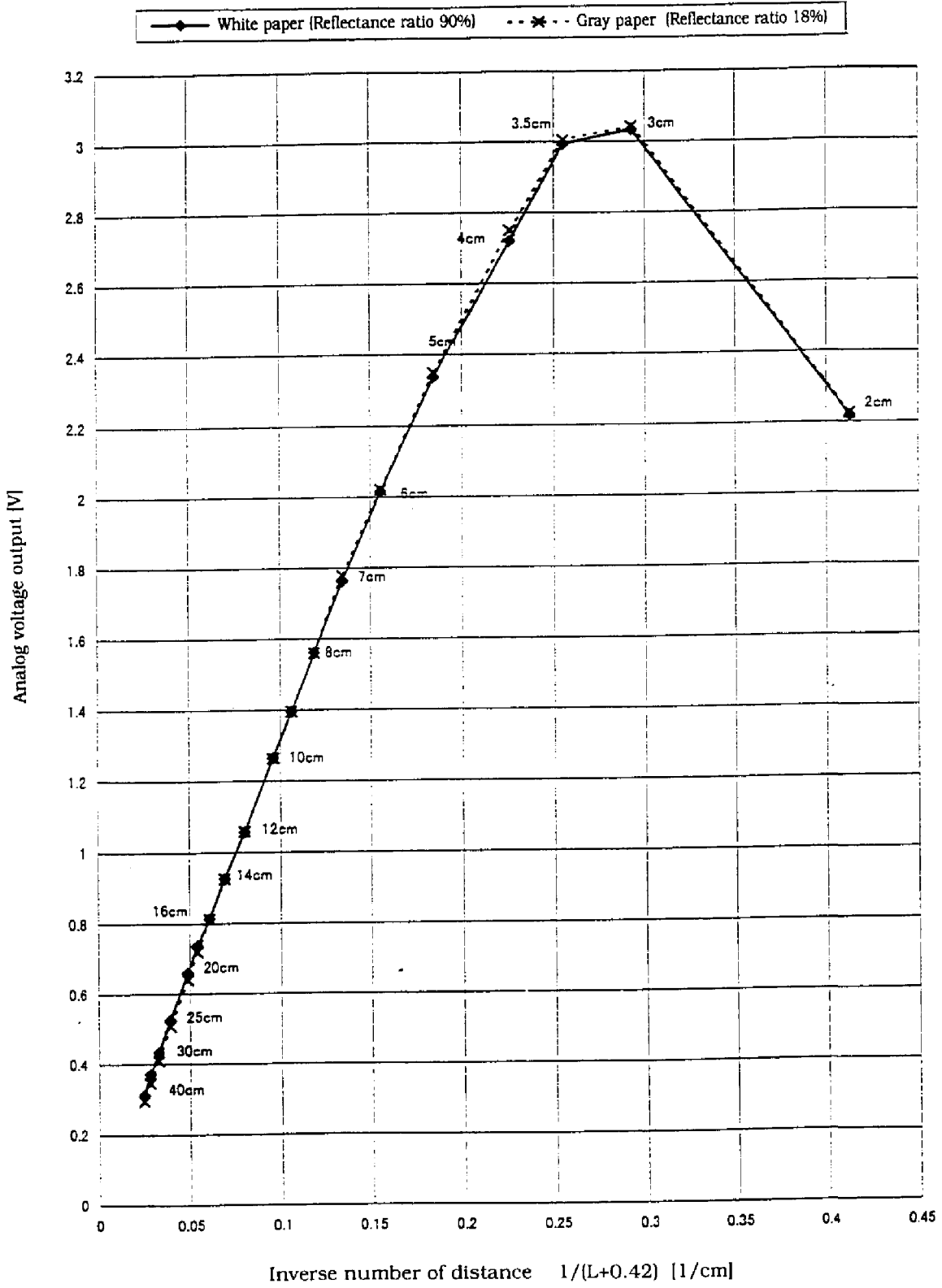

**SPECIFICATIONS ARE SUBJECT TO CHANGE WITHOUT NOTICE.**

Suggested applications (if any) are for standard use; See Important Restrictions for limitations on special applications. See Limited Warranty for SHARP's product warranty. The Limited Warranty is in lieu, and exclusive of, all other warranties, express or implied. ALL EXPRESS AND IMPLIED WARRANTIES, INCLUDING THE WARRANTIES OF MERCHANTABILITY, FITNESS FOR USE AND FITNESS FOR A PARTICULAR PURPOSE, ARE SPECIFICALLY EXCLUDED. In no event will SHARP be liable, or in any way responsible, for any incidental or consequential economic or property damage.

---

# SHARP®

## **NORTH AMERICA**

---

SHARP Microelectronics of the Americas  
5700 NW Pacific Rim Blvd.  
Camas, WA 98607, U.S.A.  
Phone: (1) 360-834-2500  
Fax: (1) 360-834-8903  
Fast Info: (1) 800-833-9437  
www.sharpsma.com

## **EUROPE**

---

SHARP Microelectronics Europe  
Division of Sharp Electronics (Europe) GmbH  
Sonninstrasse 3  
20097 Hamburg, Germany  
Phone: (49) 40-2376-2286  
Fax: (49) 40-2376-2232  
www.sharpsme.com

## **JAPAN**

---

SHARP Corporation  
Electronic Components & Devices  
22-22 Nagaike-cho, Abeno-Ku  
Osaka 545-8522, Japan  
Phone: (81) 6-6621-1221  
Fax: (81) 6117-725300/6117-725301  
www.sharp-world.com

## **TAIWAN**

---

SHARP Electronic Components  
(Taiwan) Corporation  
8F-A, No. 16, Sec. 4, Nanking E. Rd.  
Taipei, Taiwan, Republic of China  
Phone: (886) 2-2577-7341  
Fax: (886) 2-2577-7326/2-2577-7328

## **SINGAPORE**

---

SHARP Electronics (Singapore) PTE., Ltd.  
438A, Alexandra Road, #05-01/02  
Alexandra Technopark,  
Singapore 119967  
Phone: (65) 271-3566  
Fax: (65) 271-3855

## **KOREA**

---

SHARP Electronic Components  
(Korea) Corporation  
RM 501 Geosung B/D, 541  
Dohwa-dong, Mapo-ku  
Seoul 121-701, Korea  
Phone: (82) 2-711-5813 ~ 8  
Fax: (82) 2-711-5819

## **CHINA**

---

SHARP Microelectronics of China  
(Shanghai) Co., Ltd.  
28 Xin Jin Qiao Road King Tower 16F  
Pudong Shanghai, 201206 P.R. China  
Phone: (86) 21-5854-7710/21-5834-6056  
Fax: (86) 21-5854-4340/21-5834-6057

### **Head Office:**

No. 360, Bashen Road,  
Xin Development Bldg. 22  
Waigaoqiao Free Trade Zone Shanghai  
200131 P.R. China  
Email: smc@china.global.sharp.co.jp

## **HONG KONG**

---

SHARP-ROXY (Hong Kong) Ltd.  
3rd Business Division,  
17/F, Admiralty Centre, Tower 1  
18 Harcourt Road, Hong Kong  
Phone: (852) 28229311  
Fax: (852) 28660779  
www.sharp.com.hk

### **Shenzhen Representative Office:**

Room 13B1, Tower C,  
Electronics Science & Technology Building  
Shen Nan Zhong Road  
Shenzhen, P.R. China  
Phone: (86) 755-3273731  
Fax: (86) 755-3273735